

V O L V O



国四

Volvo Excavators 14.8-15.5 t 110 kW

EW140

Volvo Construction Equipment

Specifications

KEY PERFORMANCE

Engine		
Engine	Volvo	D4J
Max. power at	r/min	2 000
Net (ISO9249/SAEJ1349)	kW	105
Gross (ISO 14396/SAE J1995)	kW	110
Max. torque	Nm	609
at engine speed	r/min	1 600
Hydraulic system		
Max. flow	l/min	2 x 164
Relief valve setting pressure		
Implement	MPa	32.4 / 36.3
Travel system	MPa	36.3
Swing system	MPa	26.5
Travel system		
Tractive force (net)	kN	77.5
Travel speed (on road/off road/creep)	km/h	37/9/3.6
Swing system		
Max. swing speed	r/min	11.5
Max. swing torque	kNm	41.9

Service Refill		
Fuel tank	l	250
DEF/AdBlue® tank	l	25
Hydraulic system, total	l	200
Hydraulic tank	l	80
Engine oil	l	16
Engine coolant	l	26
Swing reduction unit	l	3.9
Transmission	l	2.5
Axle differential:		
Front axle	l	10.5
Rear axle	l	12.5
Final drive	l	4 x 2.5
Operating weight		
Boom length	m	4.4
Arm length	m	2.1
Bucket capacity	m ³	0.6
Tire type		9.00-20 18PR
Operating weight	Kg	14 850
Max. Digging Force (ISO)		
Breakout force (bucket)	kN	103.3
Tearout force (arm)	kN	79.9

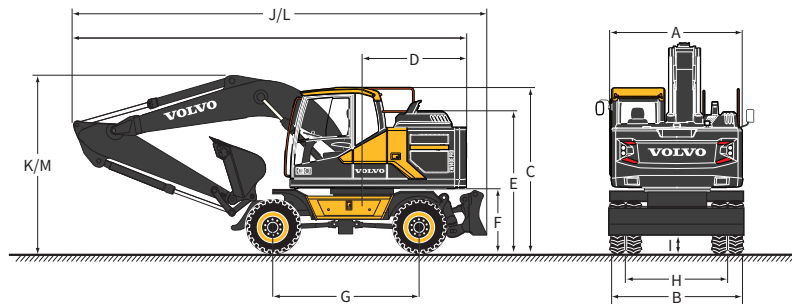

WORKING RANGES

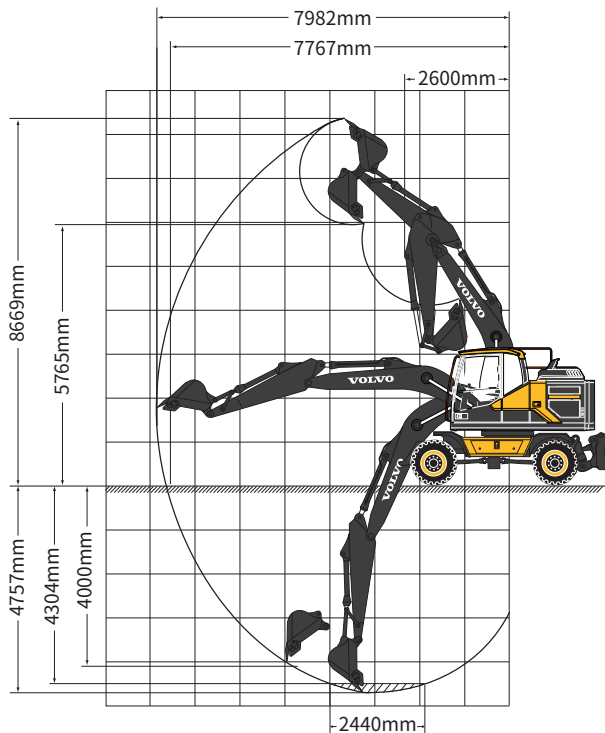

DIMENSIONS

Description	Unit	EW140
Boom	m	4.4
Arm	m	2.1
A. Overall width of upper structure	mm	2 490
B. Overall width	mm	2 500
C. Overall height of cab	mm	3 096
D. Tail swing radius	mm	2 290
E. Overall height of engine hood	mm	2 695
F. Counterweight clearance*	mm	1 208
G. Wheel base	mm	2 800
H. Tread width	mm	1 944
I. Min. ground clearance*	mm	350
J. Overall length (travel position)	mm	7 555
K. Overall height of boom (travel position)	mm	3 455
L. Overall length (transportation position)	mm	7 595
M. Overall height of boom (transportation position)	mm	3 175

V O L V O

Volvo Construction Equipment

沃尔沃建筑设备投资(中国)有限公司

中国上海市浦东新区金京路2095号 邮编:201206

电话:+86 21 3131 9888 传真:+86 21 3131 9666 中文网站:www.volvoce.com.cn

全国统一客服专线: 4000-525-168



微信公众号



沃尔沃APP