

V O L V O



Volvo Excavators 5.15-6.07 t 47.3 kW

# EW60

Volvo Construction Equipment

# Specifications

## KEY PERFORMANCE

Engine			
Engine	Volvo	D2.6H	
Max. power at	r/min	2 400	
Net (ISO9249/SAEJ1349)	kW	45.2	
Gross (ISO 14396/SAE J1995)	kW	47.3	
Max. torque	Nm	222	
at engine speed	r/min	1 500	
Hydraulic system			
Max. flow	l/min	2 x 60	
Relief valve setting pressure			
Implement	MPa	23	
Travel circuit	MPa	23	
Swing circuit	MPa	19	
Travel system			
Tractive force (net)	kN	29	
Travel speed (on road/off road)	km/h	30/10	
Swing system			
Max. slew speed	r/min	9.2	
Max. slew torque	kNm	11.6	

Service Refill			
Fuel tank	l	105	
Hydraulic system, total	l	120	
Hydraulic tank	l	76	
Engine oil	l	11	
Engine coolant	l	10	
Transmission	l	1.7	
Operating weight			
Boom length	m	2.9	
Arm length	m	1.6	
Bucket capacity	m <sup>3</sup>	0.176	
Tire type		12-16.5 12PR	
Operating weight	Kg	5 880	
Max. Digging Force (ISO)			
Breakout force (bucket)	kN	43.4	
Tearout force (arm)	kN	27.6	

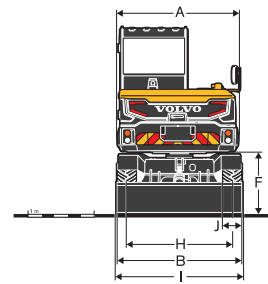
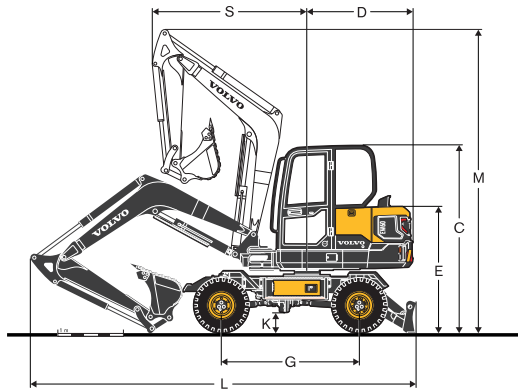

## WORKING RANGES

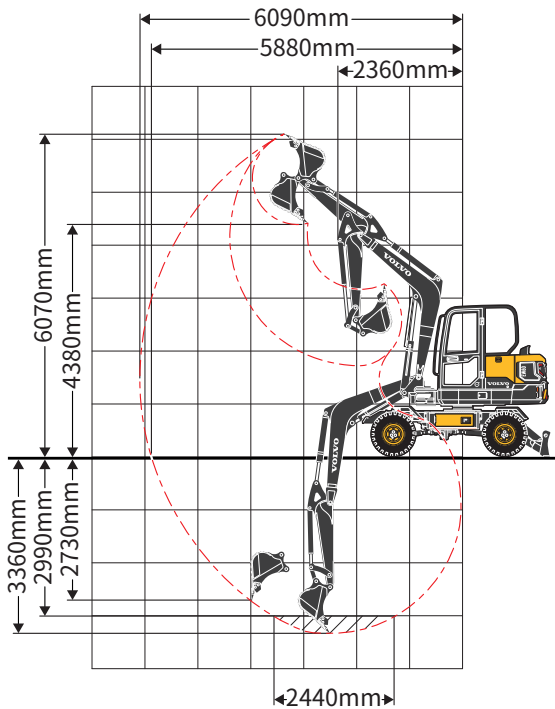

DIMENSIONS			EW60
Boom	m		2.9
Arm	m		1.6
A	Overall width of upper structure	mm	1 845
B	Overall width	mm	1 930
C	Overall height of cab	mm	2 855
D	Tail swing radius	mm	1 650
E	Overall height of engine hood	mm	1 901
F	Counterweight clearance	mm	960
G	Wheel base	mm	2 100
H	Tread width	mm	1 595
I	Dozerblade width	mm	1 930
J	Tire width	mm	305
K	Min. ground clearance	mm	295
L	Overall length	mm	5 869
M	Overall height of boom raise	mm	4 599
S	Front swing radius	mm	2 352

**V O L V O**

**Volvo Construction Equipment**

沃尔沃建筑设备投资(中国)有限公司

中国上海市浦东新区金京路2095号 邮编:201206

电话:+86 21 3131 9888 传真:+86 21 3131 9666 中文网站:www.volvoce.com.cn

全国统一客服专线: 4000-525-168



微信公众号



沃尔沃APP